

**KINGMAN  
GROUP** 

## **Edith Cowan University**

Digital Signage Project

### **CASE STUDY**

[www.kingman.com.au](http://www.kingman.com.au)  
450 Victoria Rd, Malaga WA 6090

“I have worked with Kingman on a number of digital signage projects over the last couple of years. Kingman are always readily available and consider and understand our needs and direction. The digital signs have been a huge success and commonly used within ECU as we look to increase wayfinding in the direction of digital.

We are always open to new and exciting ideas with the circular outdoor screen which was a challenge but fantastic results and method of communication.”

## **Dave Brierley**

Project Coordinator, Edith Cowan University

# Table of contents



**04** Introduction

---

**05** Behind the scenes

---

**07** LED & LCD Screens

---

**08** Cylindrical Screen

---

**13** Exterior Totems

---

**15** Library Screens

---

**17** Touch Screen Display

---

**18** Software Training



## Introduction

Kingman are the preferred signage contractors for ECU for their signage requirements, whether it's new signage, or maintenance on existing signs, Kingman have been looking after ECU for years.

Kingman are extremely proud of a recent digital signage project that we completed at ECU's campus in Joondalup.

This digital signage project with Edith Cowan University was a huge success. We were able to manufacture and install 9 different screens across their Joondalup Campus. For their digital wayfinding, we were also able to design and create the interactive content to go on the screens themselves. This made Kingman Visual the one stop shop for all their digital signage solutions on each of those 9 screens.

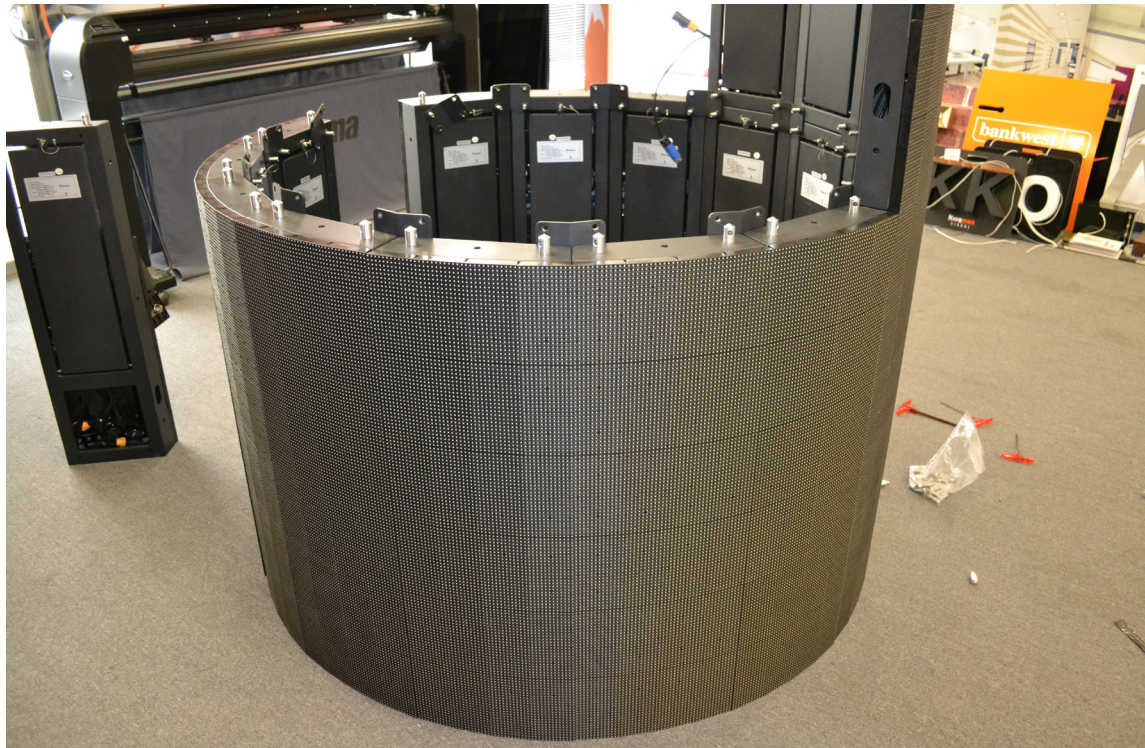

## Behind the scenes

### Sign types throughout the project:

- Modular LED screens
- Statutory signage
- Internal and external signage
- Interactive digital wayfinding
- Digital content

The entire project was successfully executed within an 8-week timeline, spanning from the initial order placement to the final delivery. Notably, we achieved a rapid turnaround by efficiently orchestrating the manufacturing of frames and completing all necessary preparations in just one week. The subsequent installation phase, encompassing intricate tasks such as wiring and commissioning, was meticulously carried out and finalized within a span of four days, from initiation to completion. This expedited process ensured the timely and seamless realization of the project's objectives.

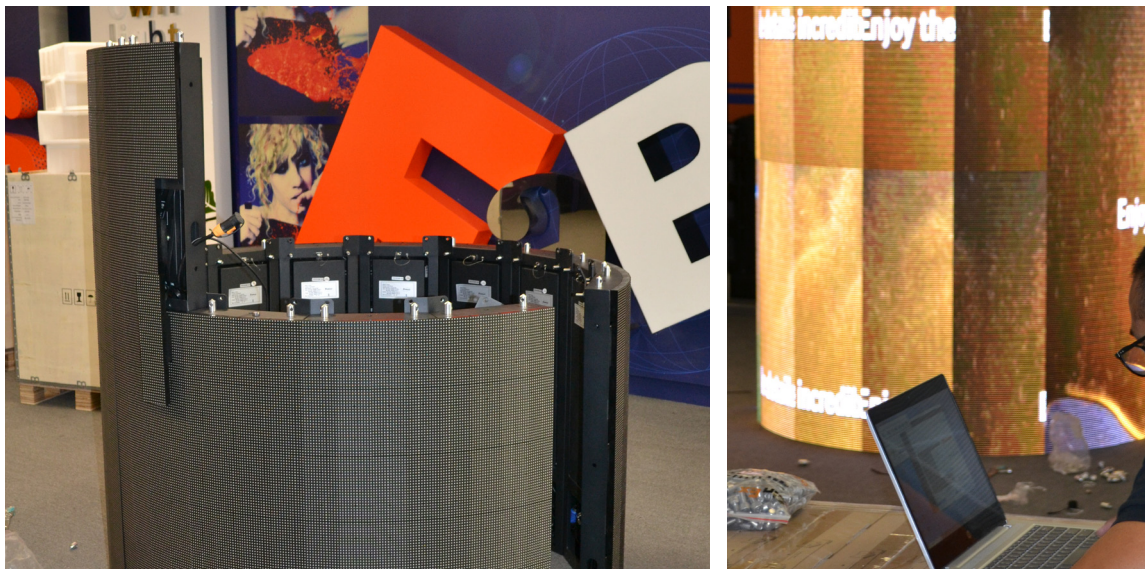

Pictured above, testing of the cylindrical screen at the Kingman factory.



Kingman love working with such innovative thinkers, and this is especially evident on their most recent digital signage project, where they commissioned Kingman to design and install a cylinder screen around an external concrete pillar. Kingman were able to come up with a fixing solution to hold the screens together around the pillar in the Student Hub.

### **Client**

- Edith Cowan University

**Pictured left,** Completion of the project at ECU's Library which included 3 screens, 2 of which had an Interactive Touch Screen display.

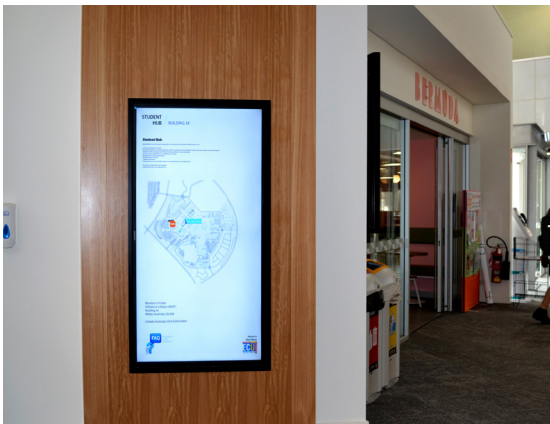
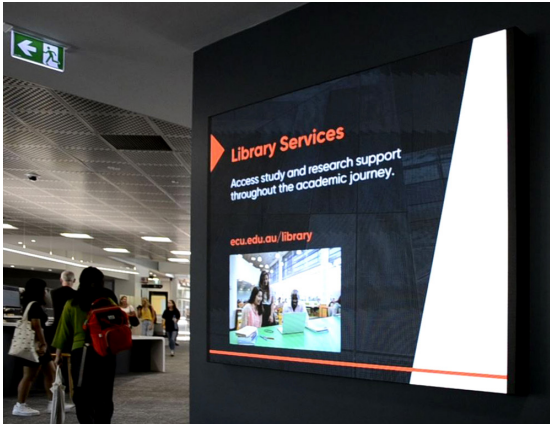

## LED & LCD Screens

The Modular LED screens exhibit remarkable versatility, allowing for the creation of a wide array of digital display styles. The potential for design innovation is virtually limitless, and Kingman stands ready to engineer customised mounting solutions that can transform any creative vision into reality.

Kingman successfully delivered and set up a total of 10 screens. This impressive installation encompassed a diverse range of locations, each with its unique purpose. Notably, among the installations was a striking Cylindrical digital screen that adds a distinctive touch to the environment.

Furthermore, Kingman's expertise extended beyond the Cylindrical screen to include 3 installations within the library, enhancing the learning environment. An additional 2 screens were strategically placed at the school of law, enriching the educational experience for students in that field. Moreover, the scope of the project expanded to encompass 3 exterior totems positioned around the campus, providing information and engagement opportunities to the entire campus community.



## Cylindrical Screen

Due to the complexity of the shape, we engineered a frame to hold the modular LED screen that was fabricated from steel and laser cut. All made here locally in WA at our state of the art signage factory in Malaga and installed around the existing pillar at ECU's common area on campus.

This included a double waterproof design. The screen itself is no small feat, weighing at nearly 750 kilograms, and standing 1600mm high.

Due to it's central location, this screen attracts plenty of eyes and is used to spread University messages, events and adverts to the students.



# Project Journey



**1. Survey Site**

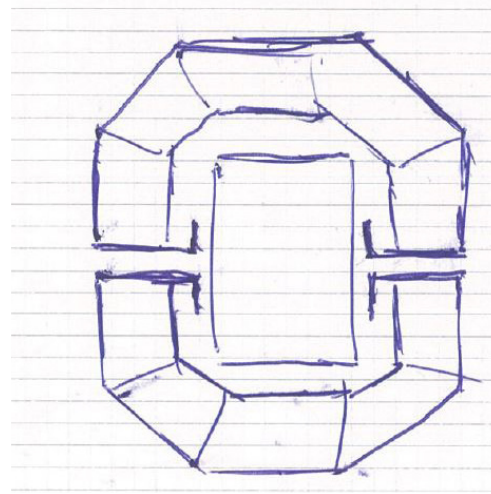

**2. Conceptualise**

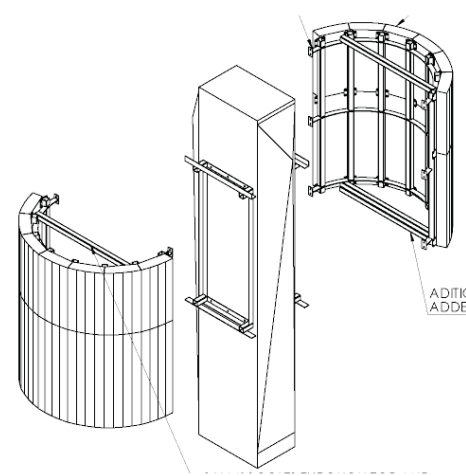

**3. Design**

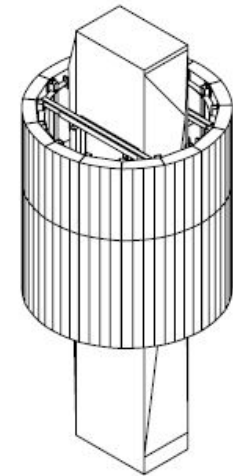

**4. Build**



**5. Configure**



**6. Test**



**7. Install**



**8. Finalise**

# 3D CAD drawings by our in-house design team

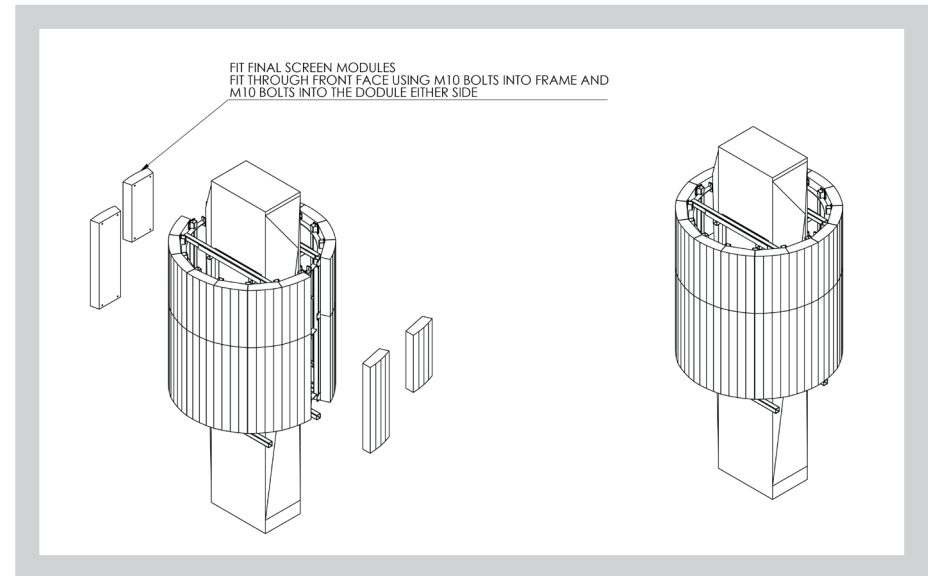
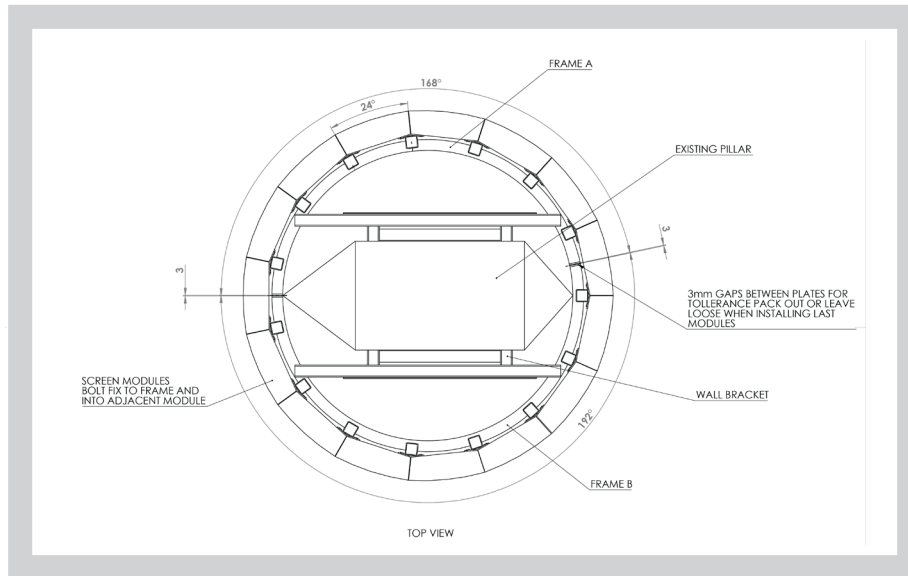
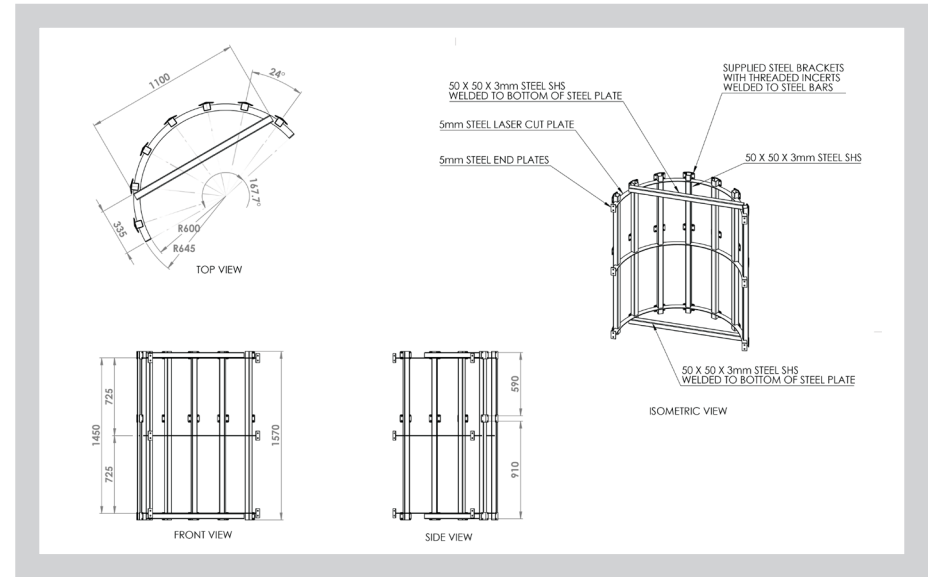
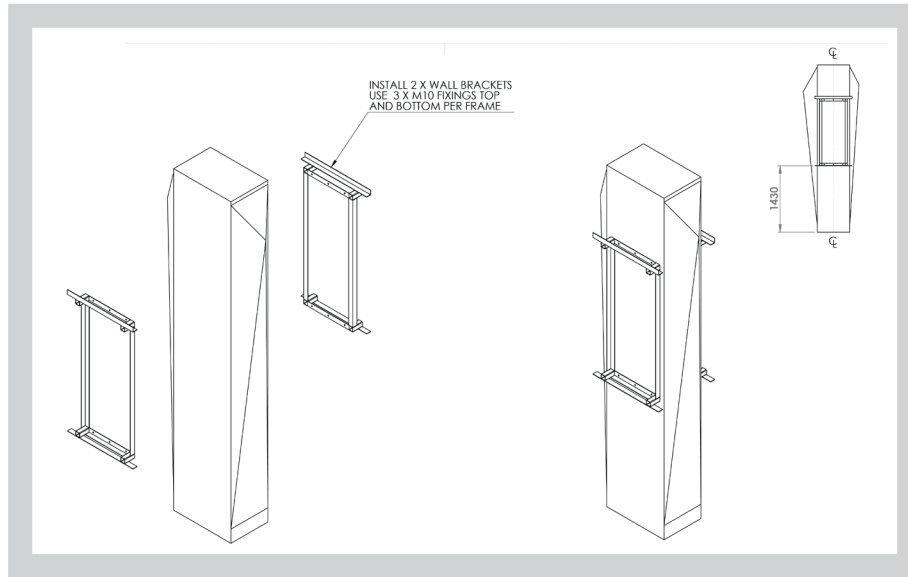

## Testing in our factory



THE BRAVEST  
THING  
YOU CAN  
BE IS  
YOURSELF.  
PRIDE © ECU





**PRIDE**  
**@**  
**ECU**

32



## Exterior Totems with Touch Screen Display

The implementation of digital signage here at ECU is simply stunning, not to mention at the forefront of digital signage technology unlike any other campus in Perth. ECU are leaders in innovation and understand the value of utilising digital signage solutions for the future generation of bright minds.

These two screens are manufactured with ECU branding, and include internal framing, an aluminium skin and a 49" Touch Screen LCD Monitor.

Standing just over two meters tall these directories are the perfect mini information centre for students and visitors alike. There are 3 throughout ECU's Joondalup campus.

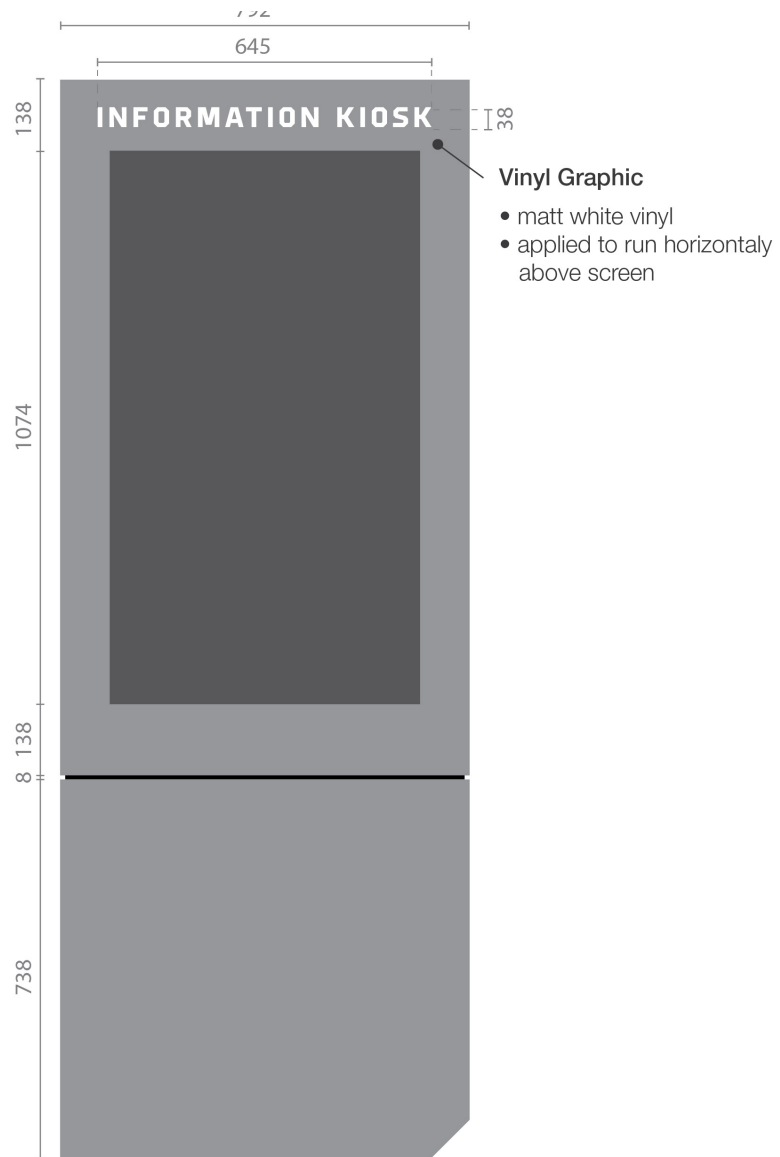

Totem 1



Totem 2

Digital Totem Information Kiosks, digital drawings



## ECU Library Screens

The 2 LCD screens at ECU Joondalup's Library have an Interactive Touch Screen display, as well as Digital Wayfinding created by our in-house design team at Kingman.

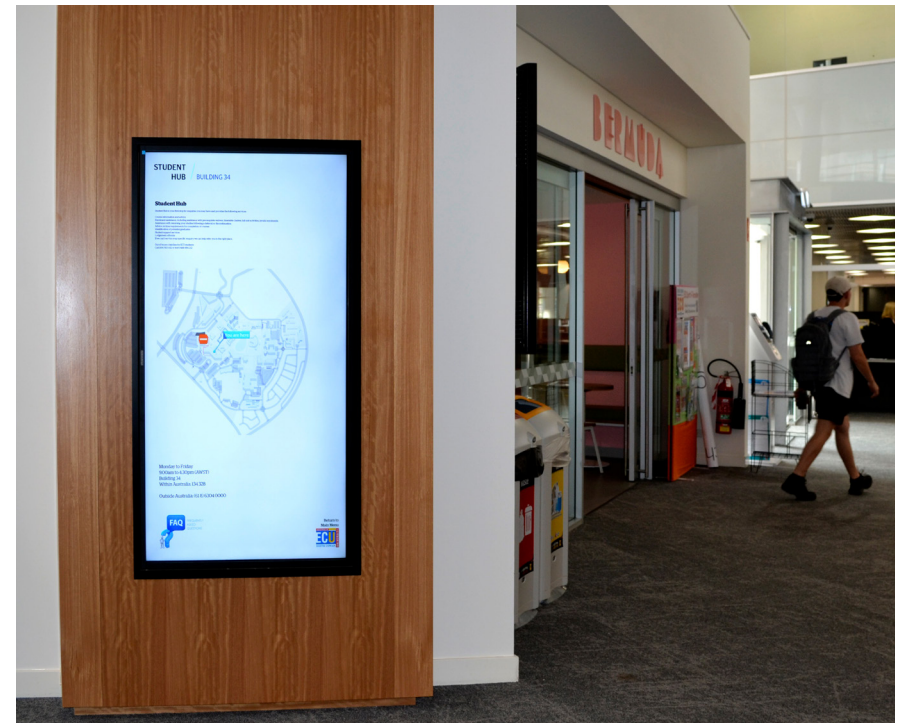





## ECU Library Screens

As well as the 2 LCD screens, we also installed a large LED screen with its own media player to seamlessly stream University content using a sophisticated content management system.

Our content management systems allow us or our clients to remotely update their content live and instantly, 24/7.

Kingman are also able to install audience analytics software that provides you with data on your viewing audience, including age, gender and duration.

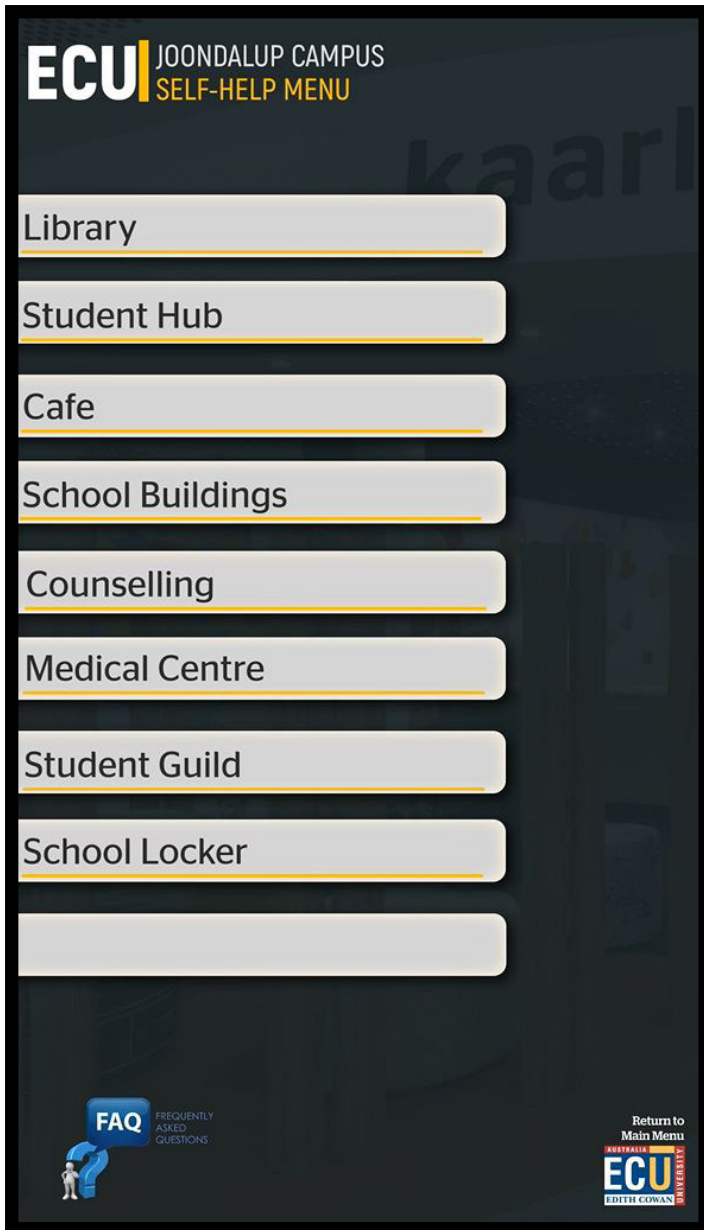

# Custom Content - Interactive Touch Screen and Digital Wayfinding

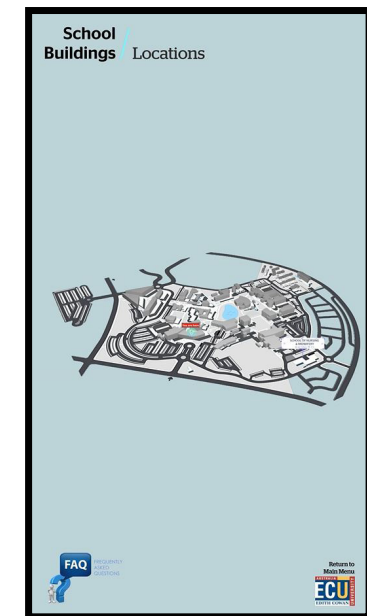
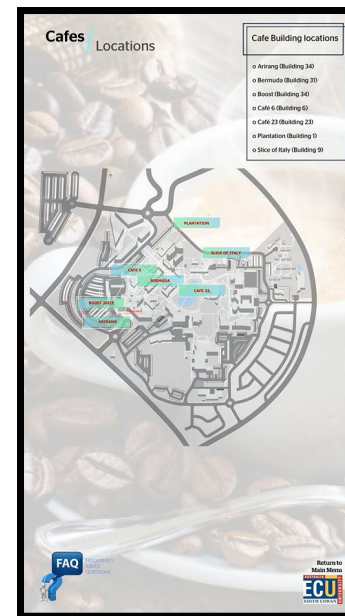
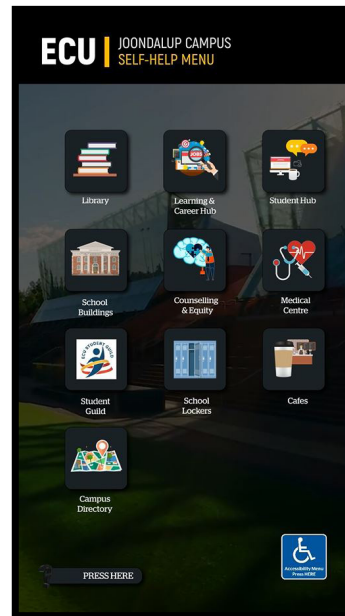

Kingman designed and created the content for the two interactive touch screen displays within the library. This included Library maps, Campus maps and a University self help menu, enabling students and visitors alike to find their way around campus.



## Software Training

Kingman conducted a comprehensive training session for all of our digital signage installations, focusing on the utilisation of a Software Support and Content Management System to effectively oversee their array of media players.

This training encompassed instructing the participants on various aspects, including software navigation, proactive troubleshooting techniques, content curation and distribution, and ensuring the optimal functionality of the entire system. Through this training, participants gained the necessary skills to proficiently manage their media players and uphold a seamless media experience.

 **KINGMAN GROUP**

450 Victoria Rd . Malaga WA 6090 | PO Box 2024, Malaga WA 6944  
www.kingmangroup.com.au | (08) 9241 9300  
abn. 56 009 389 164 | acn. 009 389 164

